

SUPERstor **ULTRA**

H E A T T R A N S F E R P R O D U C T S

INDIRECT FIRED WATER HEATERS

RESIDENTIAL

COMMERCIAL



*Heat Transfer Products, Inc., reserves the right to make product changes or updates without notice.
Heat Transfer Products will not be held liable for typographical errors in literature. For questions, please consult the factory.*

A. INSTALLATION SEQUENCE

Follow the installation instructions provided in this manual in the order shown. The order of these instructions has been set in order to provide the installer with a logical sequence of steps that will minimize potential interferences and maximize safety during heater installation.

B. SPECIAL ATTENTION BOXES

Throughout this manual you will see these special attention boxes to the right of this page which are intended to supplement the instructions and make special notice of potential hazards. These categories are as defined by the ANSI Z535.A Standard.

 **DANGER**

DANGER indicates an imminently hazardous situation which, if not avoided, will result in death or serious injury.

 **WARNING**

WARNING indicates a potentially hazardous situation which, if not avoided, could result in death or serious injury.

 **CAUTION**

CAUTION Indicates a potentially hazardous situation which, if not avoided, may result in minor or moderate injury.

CAUTION

CAUTION used without the safety alert symbol indicates a potentially hazardous situation which, if not avoided, may result in property damage.

INTRODUCING THE NEW SUPER-STOR ULTRA

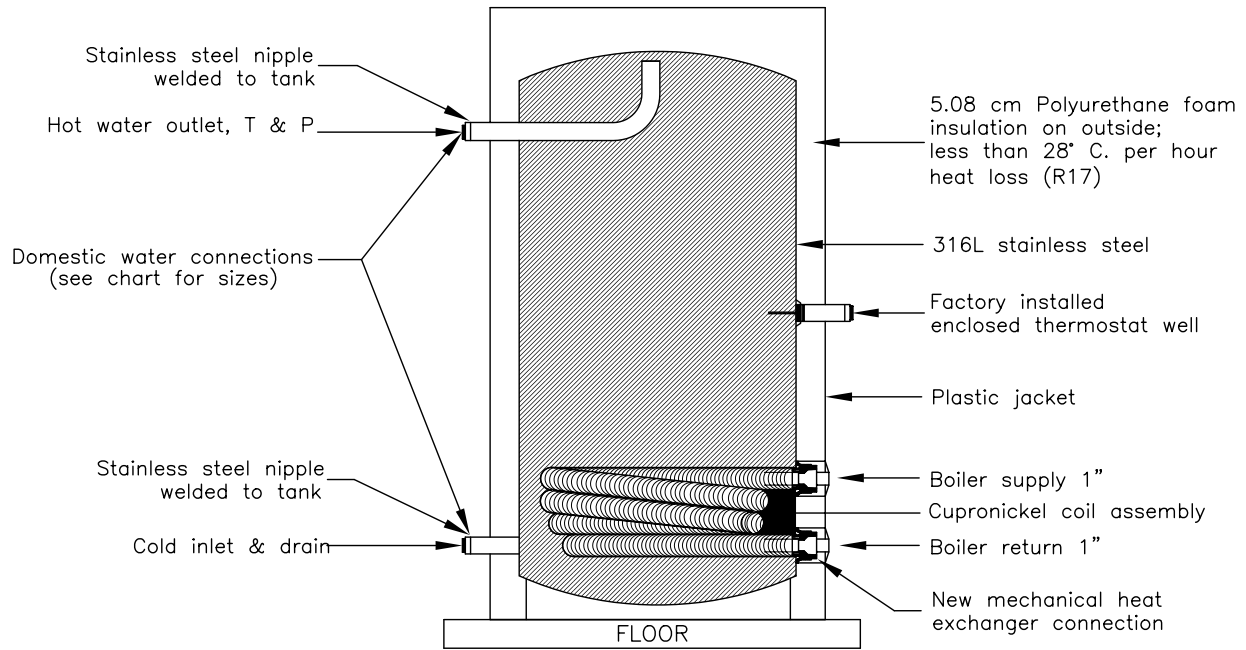

SPECIFICATIONS AND PERFORMANCE RATINGS

ULTRA RESIDENTIAL SERIES

| MODEL | DIMENSIONS | | CAPACITY | HEAT EXCH. SURFACE | RECOMM. FLOW RATE | PRESSURE DROP (FEET) | 180° BOILER WATER FIRST HOUR RATINGS* | | 200° BOILER WATER FIRST HOUR RATINGS* | |
|----------|------------|---------|----------|--------------------|-------------------|----------------------|---------------------------------------|---------|---------------------------------------|---------|
| | HT. | DIA. | | | | | 140°F | 115°F | 140°F | 115°F |
| SSU-20 | 27" | 19 1/4" | 20 | 15 SQ. FT. | 8 | 6.0 | 121 gal | 168 gal | 136 gal | 185 gal |
| SSU-30 | 39 1/2" | 19 1/4" | 30 | 15 SQ. FT. | 8 | 6.0 | 154 gal | 212 gal | 172 gal | 234 gal |
| SSU-30LB | 28 1/2" | 23 1/4" | 30 | 15 SQ. FT. | 8 | 6.0 | 169 gal | 234 gal | 189 gal | 257 gal |
| SSU-45 | 52 1/2" | 19 1/4" | 45 | 20 SQ. FT. | 10 | 7.9 | 212 gal | 292 gal | 237 gal | 322 gal |
| SSU-60 | 52 1/2" | 23 1/4" | 60 | 20 SQ. FT. | 10 | 7.9 | 266 gal | 370 gal | 298 gal | 405 gal |
| SSU-80 | 72" | 23 1/4" | 80 | 34 SQ. FT. | 12 | 9.1 | 330 gal | 440 gal | 370 gal | 503 gal |
| SSU-119 | 73 1/2" | 27" | 119 | 34 SQ. FT. | 14 | 11.3 | 423 gal | 564 gal | 474 gal | 645 gal |

*DOE TEST METHOD BASED ON 90°F. TEMPERATURE RISE, 50°/140° W/ BOILER WATER AT 180°F

| TANK SIZE | FLOOR TO BOILER SUPPLY | FLOOR TO BOILER RETURN | FLOOR TO DOMESTIC OUT | DOMESTIC CONNECTIONS | TEST PRESSURE | WORKING PRESSURE | SHIPPING WEIGHT | 180 BOILER BTU/SIZE | 200 BOILER BTU/SIZE |
|-----------|------------------------|------------------------|-----------------------|----------------------|---------------|------------------|-----------------|---------------------|---------------------|
| SSU-20 | 9" | 4 1/2" | 22" | 3/4 NPT MALE | 300 PSI | 150 PSI | 60 LBS. | 84,000 | 87,000 |
| SSU-30 | 9" | 4 1/2" | 34" | 3/4 NPT MALE | 300 PSI | 150 PSI | 72 LBS. | 102,000 | 117,000 |
| SSU-30LB | 9" | 4 1/2" | 23" | 3/4 NPT MALE | 300 PSI | 150 PSI | 79 LBS. | 114,000 | 131,000 |
| SSU-45 | 9" | 4 1/2" | 46" | 3/4 NPT MALE | 300 PSI | 150 PSI | 88 LBS. | 141,000 | 161,000 |
| SSU-60 | 9" | 4 1/2" | 46" | 1" NPT MALE | 300 PSI | 150 PSI | 110 LBS. | 174,000 | 198,000 |
| SSU-80 | 29" | 6" | 69 1/4" | 1 1/2" NPT MALE | 300 PSI | 150 PSI | 141 LBS. | 212,000 | 241,000 |
| SSU-119 | 30 1/4" | 7 1/4" | 66" | 1 1/2" NPT MALE | 300 PSI | 150 PSI | 210 LBS. | 269,000 | 301,000 |

NOTE: TANK RECOVERY FROM COLD START WILL BE BETWEEN 10-13 MINUTES WHEN SIZED WITH CORRECT FLOW RATE, BOILER SIZE, AND PRESSURE DROP RATINGS FROM LIST IN ABOVE CHART.

SPECIFICATIONS AND PERFORMANCE RATINGS

| MODEL | DIMENSIONS | | CAPACITY | HEAT EXCH. SURFACE | RECOMM. FLOW RATE | PRESSURE DROP (FEET) | 180° BOILER WATER FIRST HOUR RATINGS | | 180° BOILER WATER 2ND HOUR RATINGS | |
|--------------|------------|-------|----------|--------------------|-------------------|----------------------|--------------------------------------|---------|------------------------------------|---------|
| | HT. | DIA. | | | | | 140°F | 115°F | 140°F | 115°F |
| * SSU-45DW | 52 ½" | 19 ¼" | 45 | 20 SQ. FT. | 10 | 7.9 | 70 GAL | 108 GAL | 40 GAL | 63 GAL |
| * SSU-60DW | 52 ½" | 23 ¼" | 60 | 20 SQ. FT. | 10 | 7.9 | 90 GAL | 144 GAL | 50 GAL | 76 GAL |
| ** SSU-80DW | 72" | 23 ¼" | 80 | 20 SQ. FT. | 12 | 9.1 | 138 GAL | 215 GAL | 72 GAL | 113 GAL |
| ** SSU-119DW | 73 ½" | 27" | 119 | 20 SQ. FT. | 14 | 11.3 | 210 GAL | 326 GAL | 110 GAL | 171 GAL |

***DOE TEST METHOD BASED ON 90°F. TEMPERATURE RISE, 50°/140° W/ BOILER WATER AT 180°F**

| TANK SIZE | FLOOR TO BOILER SUPPLY | FLOOR TO BOILER RETURN | FLOOR TO DOMESTIC OUTPUT | DOMESTIC CONNECTIONS | TEST PRESSURE | WORKING PRESSURE | SHIPPING WEIGHT | 180° BOILER BTU/SIZE |
|-----------|------------------------|------------------------|--------------------------|----------------------|---------------|------------------|-----------------|----------------------|
| SSU-45DW | 9" | 4 ½" | 46" | ¾" NPT MALE | 300 PSI | 150 PSI | 88 LBS. | 107,000 |
| SSU-60DW | 9" | 4 ½" | 46" | 1" NTP MALE | 300 PSI | 150 PSI | 110 LBS. | 176,000 |
| SSU-80DW | 29" | 6" | 69 ¼" | 1 ½" NPT MALE | 300 PSI | 150 PSI | 141 LBS. | 208,000 |
| SSU-119DW | 30 ¼" | 7 ¼" | 66" | 1 ½" NPT MALE | 300 PSI | 150 PSI | 210 LBS. | 231,000 |

NOTE: TANK RECOVERY FROM COLD START WILL BE BETWEEN 55-65 MINUTES WHEN SIZED WITH CORRECT FLOW RATE, BOILER SIZE, AND PRESSURE DROP RATINGS FROM LIST IN ABOVE CHART.

*** PRESSURE DROP RATING FOR SSU-45 AND SSU-60**

6 GPM: 8.2'

7 GPM: 12.8'

**** PRESSURE DROP RATING SSU-80DW AND SSU-119 DW**

10 GPM: 13.6'

12 GPM: 15.9'

ULTRA COMMERCIAL SERIES

| MODEL | DIMENSIONS | | CAPACITY | HEAT EXCH. SURFACE | RECOMM. FLOW RATE | PRESSURE DROP (FEET) | 180° BOILER WATER FIRST HOUR RATINGS* | | 200° BOILER WATER FIRST HOUR RATINGS* | |
|----------|------------|-------|----------|--------------------|-------------------|----------------------|---------------------------------------|---------|---------------------------------------|---------|
| | HT. | DIA. | | | | | 140°F | 115°F | 140°F | 115°F |
| SSU-45C | 42 | 23 ¼" | 45 | 40 SQ. FT. | 20 | 6.8 | 314 gal | 414 gal | 351 gal | 477 gal |
| SSU-60C | 52 ½" | 23 ¼" | 60 | 40 SQ. FT. | 22 | 9.2 | 354 gal | 467 gal | 396 gal | 539 gal |
| SSU-80C | 72" | 23 ¼" | 80 | 68 SQ. FT. | 24 | 10.0 | 490 gal | 647 gal | 548 gal | 745 gal |
| SSU-119C | 73 ½" | 27" | 119 | 68 SQ. FT. | 28 | 12.7 | 637 gal | 841 gal | 713 gal | 970 gal |

***DOE TEST METHOD BASED ON 90°F. TEMPERATURE RISE, 50°/140° W/ BOILER WATER AT 180°F**

| TANK SIZE | FLOOR TO BOILER SUPPLY | FLOOR TO BOILER RETURN | FLOOR TO DOMESTIC OUT | DOMESTIC CONNECTIONS | TEST PRESSURE | WORKING PRESSURE | SHIPPING WEIGHT | 180° BOILER WATER FIRST HOUR RATINGS* BTU/SIZE | 200° BOILER WATER FIRST HOUR RATINGS* BTU/SIZE |
|-----------|------------------------|------------------------|-----------------------|----------------------|---------------|------------------|-----------------|--|--|
| SSU-45C | 9" | 4 ½" | 35" | 1 ¾" NPT MALE | 300 PSI | 150 PSI | 99 LBS. | 215,000 | 246,000 |
| SSU-60C | 9" | 4 ½" | 46" | 1" NPT MALE | 300 PSI | 150 PSI | 115 LBS. | 245,000 | 270,000 |
| SSU-80C | 29" | 6" | 69 ¼" | 1 ½" NPT MALE | 300 PSI | 150 PSI | 141 LBS. | 331,000 | 374,000 |
| SSU-119C | 30 ¼" | 7 ¼" | 66" | 1 ½" NPT MALE | 300 PSI | 150 PSI | 210 LBS. | 425,000 | 490,000 |

NOTE: TANK RECOVERY FROM COLD START WILL BE BETWEEN 10-13 MINUTES WHEN SIZED WITH CORRECT FLOW RATE, BOILER SIZE, AND PRESSURE DROP RATINGS FROM LIST IN ABOVE CHART.

CONTINUOUS FLOW PERFORMANCE CALCULATION

FIRST HOUR RATING – (.75 x TANK CAPACITY) = CONTINUOUS FLOW

EXAMPLE: SSU-45C = 314 – (.75 x 45) = 280.25
(FHR) (CONTINUOUS FLOW)

NOTE: IT IS NOT RECOMMENDED TO REDUCE BOILER INPUT WHEN USING DOUBLE WALL TANKS.

| MODEL | | GROSS OUT | GROSS OUT | GROSS OUT | GROSS OUT | GROSS OUT | GROSS OUT | GROSS OUT |
|----------|---|-----------|-----------|-----------|-----------|-----------|-----------|-----------|
| | | BTU/HR | BTU/HR | BTU/HR | BTU/HR | BTU/HR | BTU/HR | BTU/HR |
| | | 200,000 | 220,000 | 240,000 | 260,000 | 280,000 | 300,000 | 320,000 |
| | A | — | — | — | — | — | — | — |
| SSU-20 | B | — | — | — | — | — | — | — |
| | A | — | — | — | — | — | — | — |
| SSU-30 | B | — | — | — | — | — | — | — |
| | A | — | — | — | — | — | — | — |
| SSU-30LB | B | — | — | — | — | — | — | — |
| | A | — | — | — | — | — | — | — |
| SSU-45 | B | — | — | — | — | — | — | — |
| | | | | | | | | |
| | A | 370 | 370 | 370 | — | — | — | — |
| SSU-60 | B | 266 | 266 | 266 | — | — | — | — |
| | | | | | | | | |
| | A | 489 | 503 | 503 | 503 | 503 | 503 | — |
| SSU-80 | B | 359 | 370 | 370 | — | 370 | 370 | — |
| | | | | | | | | |
| | A | 457 | 470 | 543 | 627 | 645 | 645 | 645 |
| SSU-119 | B | 335 | 345 | 399 | 460 | 474 | 474 | 474 |
| | | | | | | | | |

**SUPERstor’s PRODUCT LINE CONSISTS OF VARIOUS MODELS, AVAILABLE IN DIFFERENT SIZES
CALL THE FACTORY FOR PRODUCT AND WARRANTY INFORMATION!**

"DW" (double wall heat exchanger) models are available in the 45, 60, 80, and 119 U.S. gallon sizes

"CB" (coil booster) models operate in conjunction with a tankless heater, to increase hot water storage capacity. Models are available in 30, 45, 60, 80, and 119 U.S. gallon sizes.

"C" commercial models for dual systems or commercial applications; use one coil for wood boiler, the other for the oil boiler; adaptable to solar systems as well; also good for hotels, motels, and apartments. Models are available in the 45, 60, 80, and 119 U.S. gallon sizes.

PERFORMANCE AND SIZING GUIDELINES

DETERMINE AMOUNT OF DOMESTIC HOT WATER NEEDED, THEN USE THE CHARTS BELOW TO OPTIMIZE SUPER STOR ULTRA V.S. BOILER SIZING.

COLD START BOILERS:

A. LESS THAN 90 SECONDS TO HEAT UP TO TEMPERATURE

B. GREATER THAN 90 SECONDS TO HEAT UP TO TEMPERATURE

NOTE: FIRST DRAW AT 140° F. (FOR PERFORMANCE AT 115° F, MULTIPLY BY 1.56 FOR MINUTES OF WATER DRAW)

| MODEL | | 2.0 GPM | 2.5 GPM | 3.0 GPM | 3.5 GPM | 4.0 GPM | 4.5 GPM | 5.0 GPM |
|----------|---|---------|---------|---------|---------|---------|---------|---------|
| SSU-20 | A | 9.5 | 8.0 | 7.0 | 5.5 | 4.5 | 4.0 | 3.5 |
| | B | 8.5 | 7.5 | 6.5 | 5.0 | 4.0 | 3.5 | 3.0 |
| SSU-30 | A | 16.0 | 13.0 | 10.0 | 7.5 | 6.0 | 5.5 | 5.0 |
| | B | 14.0 | 12.0 | 9.0 | 7.0 | 5.5 | 5.0 | 4.5 |
| SSU-30LB | A | 18.0 | 14.0 | 12.0 | 9.0 | 6.5 | 6.0 | 5.5 |
| | B | 17.0 | 12.0 | 10.0 | 8.0 | 6.0 | 5.5 | 5.0 |
| SSU-45 | A | 23.0 | 18.0 | 14.0 | 11.0 | 8.5 | 7.5 | 7.0 |
| | B | 18.0 | 15.0 | 13.0 | 10.0 | 7.5 | 7.5 | 6.5 |
| SSU-45C | A | ∞ | ∞ | ∞ | 29.0 | 20.0 | 17.0 | 14.0 |
| | B | 45.0 | 24.0 | 26.0 | 18.0 | 16.0 | 13.0 | 10.0 |
| | | | | | | | | |
| SSU-60 | A | ∞ | ∞ | ∞ | ∞ | 36.0 | 30.0 | 22.0 |
| | B | ∞ | ∞ | ∞ | ∞ | 29.0 | 19.0 | 12.0 |
| SSU-60C | A | ∞ | ∞ | ∞ | ∞ | ∞ | 46.0 | 29.0 |
| | B | ∞ | ∞ | ∞ | ∞ | ∞ | 30.0 | 21.0 |
| | | | | | | | | |
| SSU-80 | A | ∞ | ∞ | ∞ | ∞ | ∞ | ∞ | ∞ |
| | B | ∞ | ∞ | ∞ | ∞ | ∞ | ∞ | ∞ |
| SSU-80C | A | ∞ | ∞ | ∞ | ∞ | ∞ | ∞ | ∞ |
| | B | ∞ | ∞ | ∞ | ∞ | ∞ | ∞ | ∞ |
| | | | | | | | | |
| SSU-119 | A | ∞ | ∞ | ∞ | ∞ | ∞ | ∞ | ∞ |
| | B | ∞ | ∞ | ∞ | ∞ | ∞ | ∞ | ∞ |
| SSU-119C | A | ∞ | ∞ | ∞ | ∞ | ∞ | ∞ | ∞ |
| | B | ∞ | ∞ | ∞ | ∞ | ∞ | ∞ | ∞ |
| | | | | | | | | |

NOTE: THIS INFORMATION IS BASED ON BOILER SIZE CONFORMING TO THE MINIMUM BTU/H REQUIRED TO ACHIEVE FIRST HOUR RATINGS, OBTAINABLE FROM CHART ABOVE.

∞ indicates infinity (continous duty)

NOTE: MINIMUM BTU/H REQUIRED TO ACHIEVE FIRST HOUR RATING

| MODEL | GROSS OUTPUT | 140° F 90° F ΔT GAL/HR | 127° F 77° F ΔT GAL/HR | 115° F 65° F ΔT GAL/HR |
|----------|--------------|---------------------------|---------------------------|---------------------------|
| SSU-20 | 84,000 | 121 | 140 | 168 |
| SSU-30 | 102,000 | 154 | 180 | 212 |
| SSU-30LB | 113,000 | 169 | 198 | 234 |
| SSU-45 | 141,000 | 212 | 248 | 292 |
| SSU-45C | 215,000 | 314 | 367 | 414 |
| | | | | |
| SSU-60 | 174,000 | 266 | 311 | 370 |
| SSU-60C | 245,000 | 354 | 414 | 467 |
| | | | | |
| SSU-80 | 212,000 | 330 | 386 | 440 |
| SSU-80C | 331,000 | 490 | 573 | 647 |
| | | | | |
| SSU-119 | 269,999 | 423 | 495 | 564 |
| SSU-119C | 425,000 | 637 | 745 | 841 |
| | | | | |

LOCATION

Choose a location for your water heater centralized to the piping system. You must also locate the Super Stor Ultra where it will not be exposed to freezing temperatures. Additionally, you will need to place the water heater so that the controls, drain, and inlet/outlets are easily accessible. This appliance must not be installed outdoors, as it is certified as an indoor appliance, and must also be kept vertical on a level surface.

⚠ CAUTION

This unit must be placed where leakage from the relief valve, leakage from the related piping, or leakage from the tank or connections, will not result in damage to the surrounding areas, or to the lower floors of the building. A water heater should always be located in an area with a floor drain or installed in a drain pan suitable for water heaters. Heat Transfer Products Inc. shall not be held liable for any such water damage.

⚠ DANGER

This water heater must not be located near flammable liquids such as Gasoline, Adhesives, Solvents, Paint Thinners, Butane, Liquefied Propane, etc.; as the controls of this appliance could ignite vapors causing an explosion.

OPERATING YOUR SUPER STOR ULTRA

“Boiler high limit should be at least 20° higher than the Super Stor Ultra temperature. Set the low limit of the boiler control at the minimum setting – this will call the burner on, only to satisfy the tank control. The differential should be 10° to 15°, if your control is adjustable, be sure that it is in that range. We recommend a temperature setting of 119°F, or in accordance with local and state codes for normal operation. You may prefer a setting of either higher or lower temperature, to satisfy your needs. A mixing valve in connection with a high temperature setting may be used for high demand applications (spas, hot tubs, whirlpools)”

⚠ CAUTION

Risk of scald injury increases as you increase water temperature! If draining of the SuperStor Ultra is necessary, open the T & P valve or a hot water tap, to prevent vacuum buildup in the tank and piping.

PLUMBING

It is mandatory that all plumbing is done in accordance with all local and state plumbing codes, or warranty will be voided. It is also necessary on all mechanical connections, that you use both thread tape and pipe dope.

NOTE: WHEN FILLING THE SUPER STOR ULTRA, MAKE SURE THAT YOU OPEN THE HOT WATER TAP TO RELEASE AIR IN THE TANK AND PIPING.

BOILER CONNECTIONS

Use a 1" nominal minimum tube size, wherever you are using zone valves or circulators; where a 1" zone valve and 1" tube is required.

On the tank, the boiler supply is to be connected to the outlet of the circulator. The inlet of the circulator is to be connected to the "HOT OUTLET" side of the boiler. Be sure that the arrow on the circulator is facing toward the flow direction, (See pressure drop sizing for circulator, page 8). On the tank, the boiler return is to be connected to the return side of the boiler. The return(s) from heating loop(s) should have a flow check or swing check valve installed before the return pipe from the tank.

In a steam boiler, the tank supply must be connected to the boiler, well below the minimum water level. A strainer and a drain valve should be installed at the boiler for periodic draining of scale and sludge. Banging and steam bound traps will occur if the boiler water supplied to heat exchange has steam, or is slightly above the low water cut-out.

It is possible to use live steam in the heat exchanger of the Super Stor Ultra 80 and Super Stor Ultra 119 only. Consult factory for suggested piping and required components. The Ultra commercial series Super Stor Ultra 80C and Super Stor Ultra 119C are also included in this application.

⚠ DANGER

⚠ DANGER



Water temperature over 125° F. can cause severe burns instantly, or death from scalds. Children, disabled, and elderly are at highest risk of being scalded. See instruction manual before setting temperature at water heater. Feel water before bathing or showering! Temperature limiting valves are available.

⚠ DANGER



⚠ WARNING

Never use dielectric unions or galvanized steel fittings on any domestic water connections. Use only copper or brass fittings. Teflon thread sealant must be used on all connections.

COLD WATER INLET

Use both thread tape and pipe dope and connect an NPT brass tee. On the run, install a brass drain valve. In the branch, install an NPT male X $\frac{3}{4}$ " (minimum) tube adapter. A shut off valve between city water supply and tank inlet is recommended for ease of service at a later date. It may be recommended to use a back flow preventer – check your local codes

If a back flow preventer, or a return valve is not used; a thermal expansion tank must be installed on the cold water supply, between the tank and valve. If the tank is replacing a tankless coil in the boiler, disconnect coil plumbing and use the cold inlet pipe and hot water outlet pipes for the Super Stor Ultra tank.

⚠ CAUTION

DO NOT PLUG TUBE OUTLET IN TANKLESS COIL.

DOMESTIC HOT WATER OUTLET CONNECTION

Use both thread tape and pipe dope, and connect an NPT brass tee. In the run of the brass tee, install an NPT brass T & P valve long element, for hot water storage tanks (Required by local codes, but not less than the valve certified as meeting the requirements for relief valves for hot water heaters (ANSI Z212B-1984), by a nationally recognized lab that maintains periodic inspection of production listed equipment. Make sure that the relief valve is sized to the BTU/Hour capacity and storage capacity of the water heater. The temperature and pressure relief valve must be plumbed down so discharge can exit only 6" above, or at any distance below the structural floor; and cannot be in contact with any live electrical parts.

⚠ WARNING

Following installation of the T & P Relief Valve, the valve lever MUST be operated AT LEAST ONCE A YEAR by the water heater owner to ensure that waterways are clear.

Certain naturally occurring mineral deposits may adhere to the valve, blocking waterways, rendering it inoperative. When the lever is operated, hot water will discharge if the waterways are clear. **PRECAUTIONS MUST BE TAKEN TO AVOID PERSONAL INJURY FROM CONTACT WITH HOT WATER AND TO AVOID PROPERTY DAMAGE. BEFORE operating lever, check to see that a discharge line is connected to the valve, directing the flow of hot water from the valve to a proper place of disposal. If no water flows when the lever is operated, replacement of the valve is required. TURN THE WATER HEATER "OFF" AND CALL A PLUMBER IMMEDIATELY.**

This device is designed for emergency safety relief and shall not be used as an operating control. A relief valve functions, in an emergency, by discharging water. Therefore, it is essential that a discharge line be piped from the valve in order to carry the overflow to a safe place of disposal. The discharge line must be same size as the valve outlet must pitch downward from the valve and terminate at least 6" above a drain where any discharge will be clearly visible.

CAUTION

REINSPECTION OF T&P RELIEF VALVES: Temperature and Pressure Relief Valves should be inspected **AT LEAST ONCE EVERY THREE YEARS**, and replaced, if necessary, by a licensed plumbing contractor or qualified service technician, to ensure that the product has not been affected by corrosive water conditions and to ensure that the valve and discharge line have not been altered or tampered with illegally. Certain naturally occurring conditions may corrode the valve and its components over time, rendering the valve inoperative. Such conditions can only be detected if the valve and its components are physically removed and inspected. **Do not attempt to conduct an inspection on your own.** Contact your plumbing contractor for a re-inspection to assure continuing safety.

DANGER

WARNING: FAILURE TO REINSPECT THIS VALVE AS DIRECTED COULD RESULT IN UNSAFE TEMPERATURE OR PRESSURE BUILDUP WHICH CAN RESULT IN SERIOUS INJURY OR DEATH AND/OR SEVERE PROPERTY DAMAGE.

(Optional to save additional energy dollars) In the bottom of the tee (branch) vertically down, install an NPT tube adapter. Then install two sweat street 90° elbows. This acts as a thermal loop to prevent thermal siphon action of hot water

EXPANSION TANK

A thermal expansion tank may be required in the system designed for potable water use, to offset the expansion of stored water as the temperature is elevated (only in systems where there is no return valve, a back flow preventer, a water meter, or anywhere pressure can build up as the water is heated). See typical expansion tank on following page.

CONTROL

Install control element into well and tighten in place with screws on control body. Thermal conductive paste is recommended. Once the control is operational, it is very important to make sure the control is maintaining the desired operating temperature.

WIRING

All wiring is to be done in accordance with all applicable local and state codes. Turn off all power related to the boiler starting and wiring procedures. It is recommended that a disconnect switch be installed between the boiler control and water heater.

PRESSURE DROP SIZING FOR CIRCULATOR

You must have a flow rate, from chart on page 3, on the boiler circulator for the water; or the published ratings cannot be achieved. The chart below represents the tube run and the water heater ONLY, and does not include any flow checks or zone valves. That resistance must be added to the value found in the chart below.

| PRESSURE DROP FOR TUBE LENGTH OF 1" COPPER, AND FOR SIX 90 DEGREE ELBOWS, AND ON TEE ON THE RUN | | | | | |
|--|------------|------------|------------|------------|------------|
| TUBE SIZE | 20' | 30' | 40' | 50' | 60' |
| 6 GPM | 8.63' | 8.93' | 9.23' | 9.53' | 9.8' |
| 7 GPM | 11.3' | 11.77' | 12.24' | 12.7' | 13.1' |
| 10 GPM | 10.25' | 11.1' | 11.95' | 12.8' | 13.66' |
| 12 GPM | 11.3' | 13.2' | 14.1' | 15' | 16' |
| 14 GPM | 15.3' | 16.4' | 17.5' | 18.6' | 19.8' |
| 14 GPM | 15.3' | 16.4' | 17.5' | 18.6' | 19.8' |

| PRESSURE DROP FOR TUBE LENGTH OF 1¼" COPPER, TEN 90° ELBOWS AND 2 TEES | | | | | |
|---|------------|------------|------------|------------|------------|
| TUBE SIZE | 20' | 30' | 40' | 50' | 60' |
| 20 GPM | 10.9' | 11.7' | 12.6' | 13.4' | 14.3' |
| 22 GPM | 14.0' | 15.0' | 16.0' | 17.0' | 18.0' |
| 24 GPM | 16.2' | 17.5' | 18.8' | 20.1' | 21.5' |
| 28 GPM | 20.4' | 22.0' | 23.6' | 25.2' | 26.8' |

TYPICAL MIXING VALVE

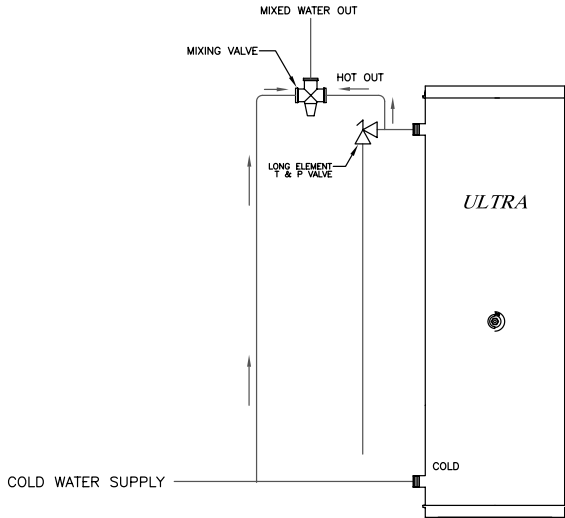

TYPICAL EXPANSION TANK

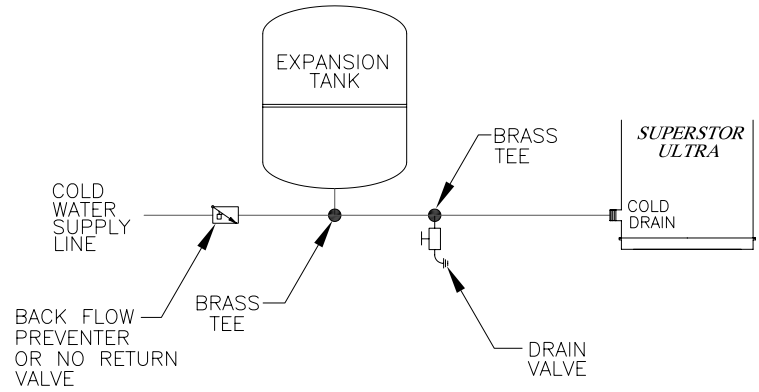

TYPICAL INSTALLATION USING ZONE VALVES

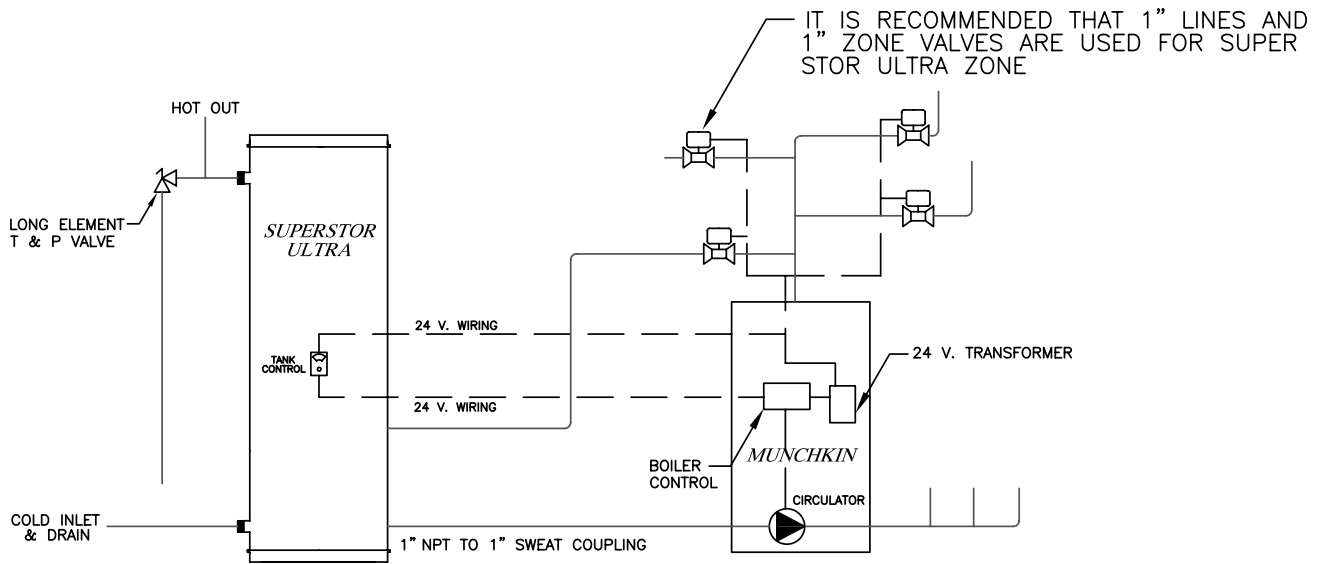

NOTE: IF A BACK FLOW PREVENTER OR A NO RETURN VALVE IS INSTALLED, A THERMAL EXPANSION TANK IS REQUIRED ON THE COLD WATER INLET BETWEEN THE SUPERSTOR ULTRA AND THE BACKFLOW PREVENTER.

TYPICAL INSTALLATION USING CIRCULATORS

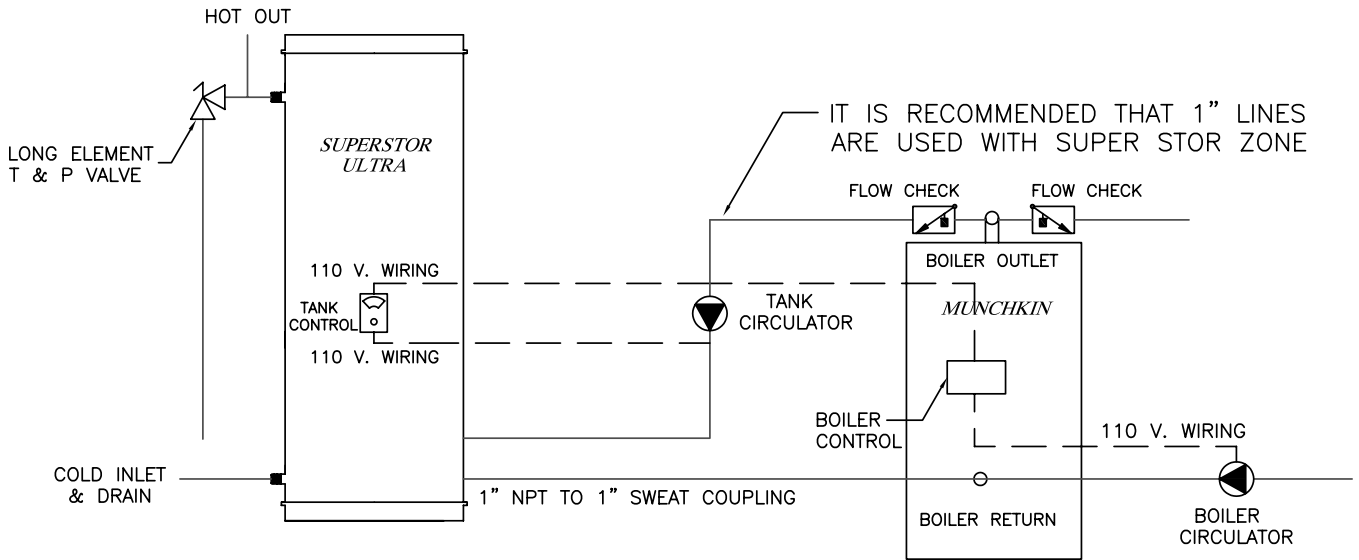

NOTE: IF A BACKFLOW PREVENTER OR A NO RETURN VALVE IS INSTALLED, A THERMAL EXPANSION TANK IS REQUIRED ON THE COLD WATER INLET BETWEEN THE SUPER STOR ULTRA AND THE BACKFLOW PREVENTER.

TYPICAL INSTALLATION USING A ZONE VALVE (3-WAY)

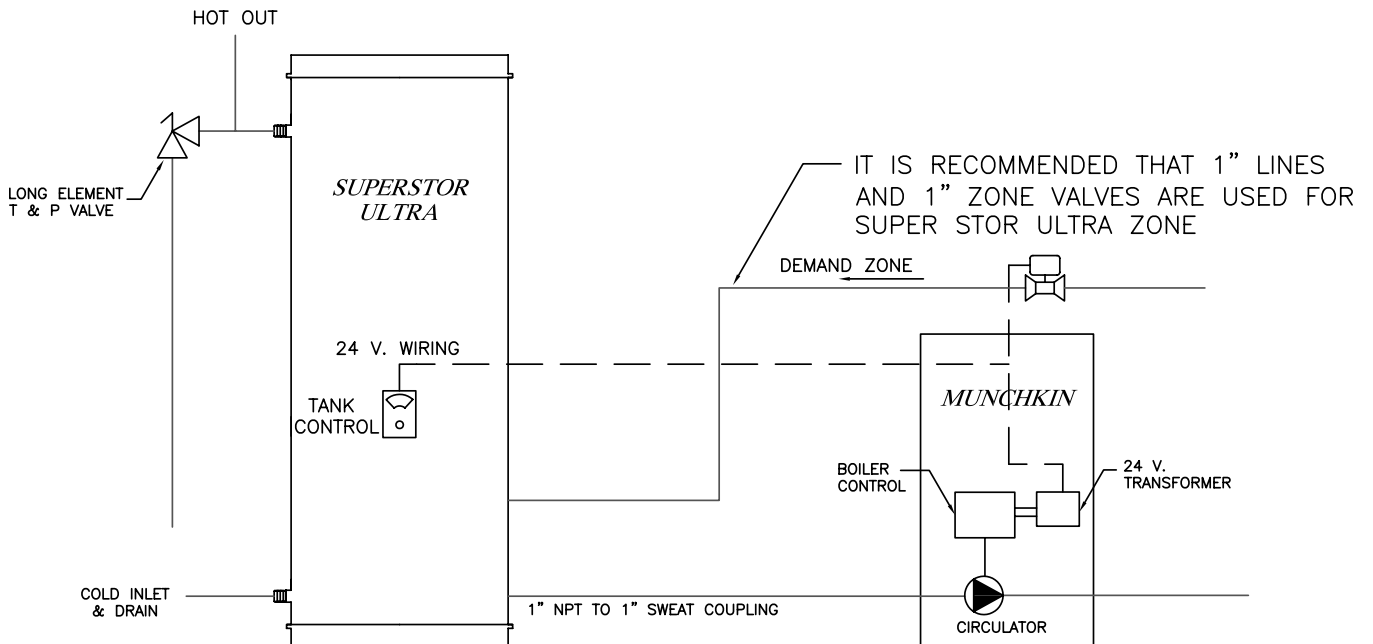

NOTE: IF A BACKFLOW PREVENTER OR A NO RETURN VALVE IS INSTALLED, A THERMAL EXPANSION TANK IS REQUIRED ON THE COLD WATER INLET BETWEEN THE SUPER STOR ULTRA AND THE BACKFLOW PREVENTER.

TYPICAL DP INSTALLATIONS

NOTE: ON MULTIPLE SOURCE APPLICATIONS, USE A HONEYWELL L4081-A-1148, WHICH HAS TWO LIMIT SETTINGS. THIS ALLOWS THE SOLAR PANEL, WOOD STOVE, OR THE WOOD/COAL BOILER TO OPERATE ON THE TANK HIGH SETTING, AND THE TANK LOW LIMIT SETTING FOR CONVENTIONAL BOILER BACK-UP.

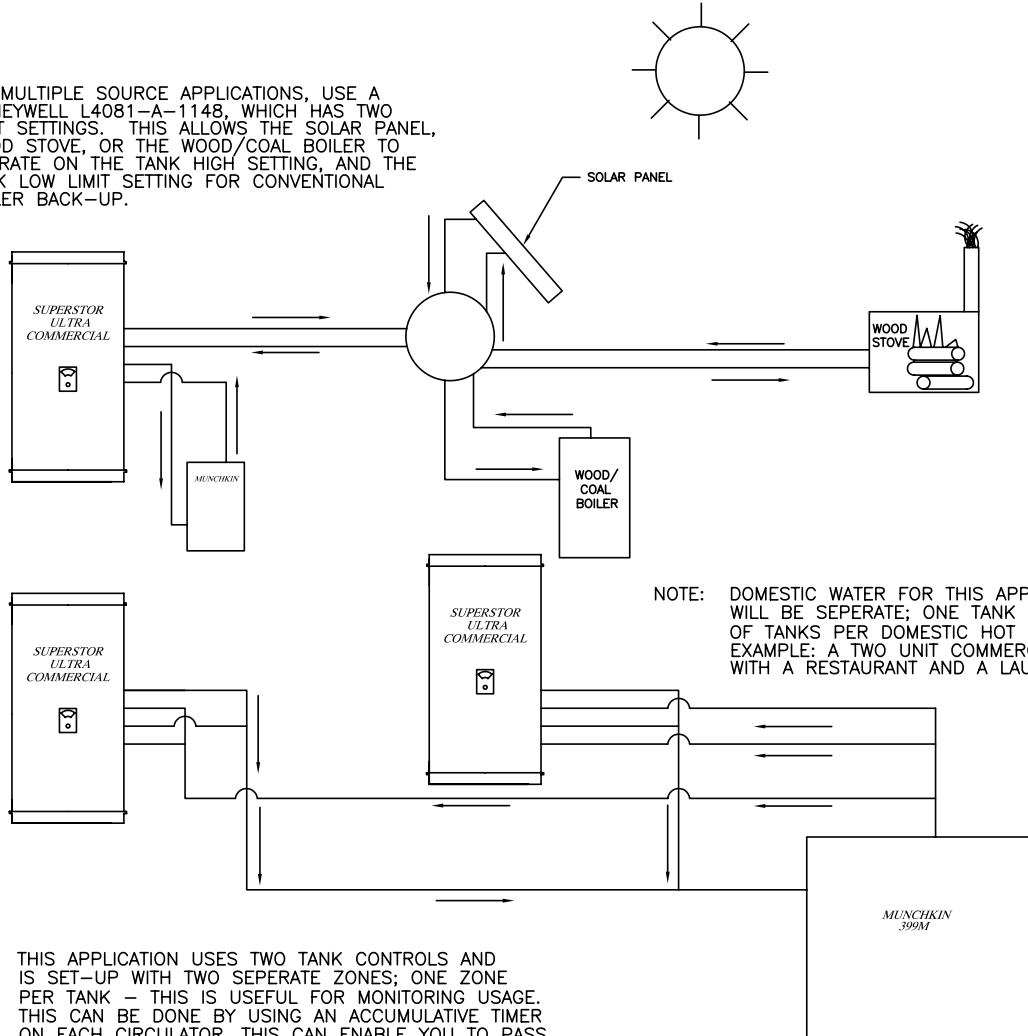

NOTE: DOMESTIC WATER FOR THIS APPLICATION WILL BE SEPERATE; ONE TANK OR BANK OF TANKS PER DOMESTIC HOT SUPPLY LINE. EXAMPLE: A TWO UNIT COMMERCIAL BUILDING WITH A RESTAURANT AND A LAUNDROMAT.

NOTE: THIS APPLICATION USES TWO TANK CONTROLS AND IS SET-UP WITH TWO SEPERATE ZONES; ONE ZONE PER TANK - THIS IS USEFUL FOR MONITORING USAGE. THIS CAN BE DONE BY USING AN ACCUMULATIVE TIMER ON EACH CIRCULATOR. THIS CAN ENABLE YOU TO PASS ALONG FUEL COST ADJUSTMENTS IN A MULTI-USAGE RENTAL PROPERTY.

SUPERSTOR WITH STORAGE TANK TYPICAL INSTALLATION

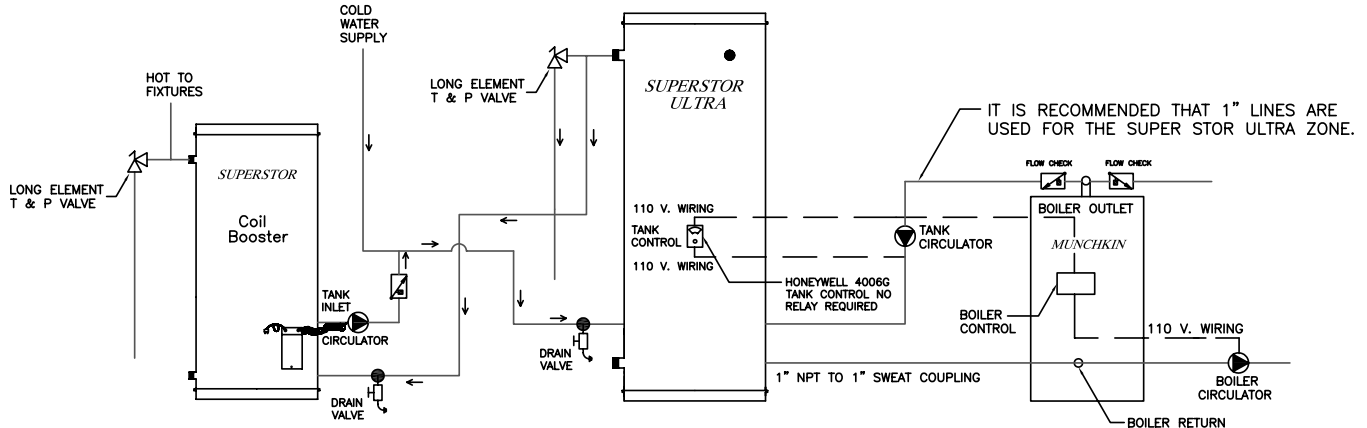

NOTE: IF A BACKFLOW PREVENTER OR A NO RETURN VALVE IS INSTALLED, A THERMAL EXPANSION TANK IS REQUIRED ON THE COLD WATER INLET BETWEEN THE SUPER STOR ULTRA AND THE BACKFLOW PREVENTER.

MULTIPLE TANK INSTALLATIONS

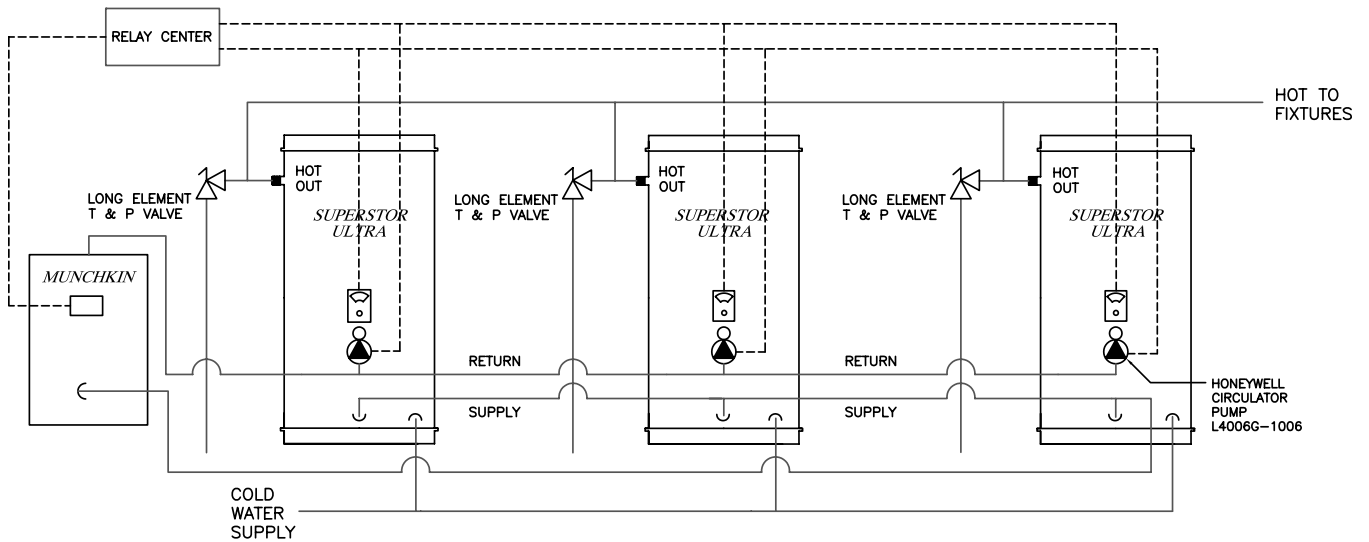

NOTE: ALL PIPING IN PARALLEL USED FOR LARGE DUMPS OF HOT WATER; HIGH USAGE, SHORT DURATION.

TYPICAL STEAM BOILER

NOTE: WATER LINE MUST REMAIN ABOVE BOILER OUTLET TO WATER HEATER AT ALL TIMES

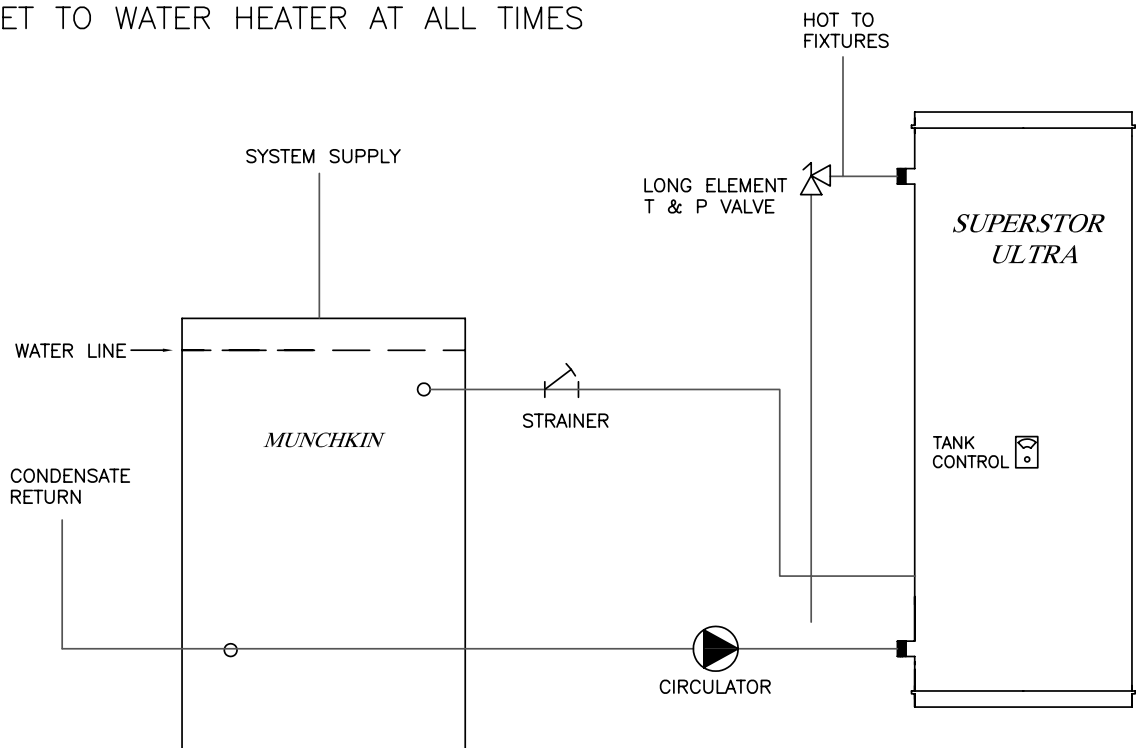

ZONING WITH CIRCULATORS WITH R845 RELAY

THIS DIAGRAM SHOWS CONNECTIONS FOR EITHER A LINE VOLTAGE OR 24V MANIFOLD GAS VALVE.
 (NOTE: THIS DIAGRAM IS NOT RECOMMENDED FOR NORMAL STACK-MOUNTED OIL BURNER CONTROLS BECAUSE RAPID CYCLING OF THE LOW LIMIT-CIRCULATOR CONTROL MAY CAUSE THE OIL BURNER CONTROL TO LOCK OUT ON SAFETY)

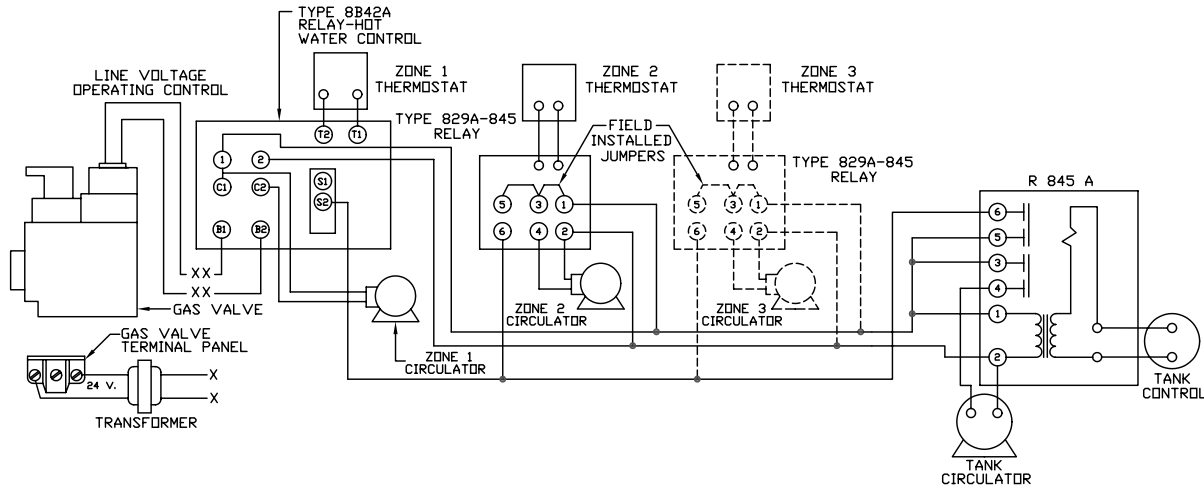

CAUTION: TERMINAL '6' FROM TYPE 829A-845 RELAYS MUST BE WIRED TO TERMINAL 'S2' ON THE 8B42A TYPE RELAY HOT-WATER CONTROL AS SHOWN TO MAKE CERTAIN THAT THE HIGH LIMIT IS WIRED INTO THE CIRCUIT.

FIG. 1

ZONING WITH CIRCULATORS USING R8182D AND D.P.S.T. NO RELAY REQUIRED

THIS DIAGRAM SHOWS CONNECTIONS FOR EITHER A LINE VOLTAGE OR 24V MANIFOLD GAS VALVE.
 (NOTE: THIS DIAGRAM IS NOT RECOMMENDED FOR NORMAL STACK-MOUNTED OIL BURNER CONTROLS BECAUSE RAPID CYCLING OF THE LOW LIMIT-CIRCULATOR CONTROL MAY CAUSE THE OIL BURNER CONTROL TO LOCK OUT ON SAFETY)

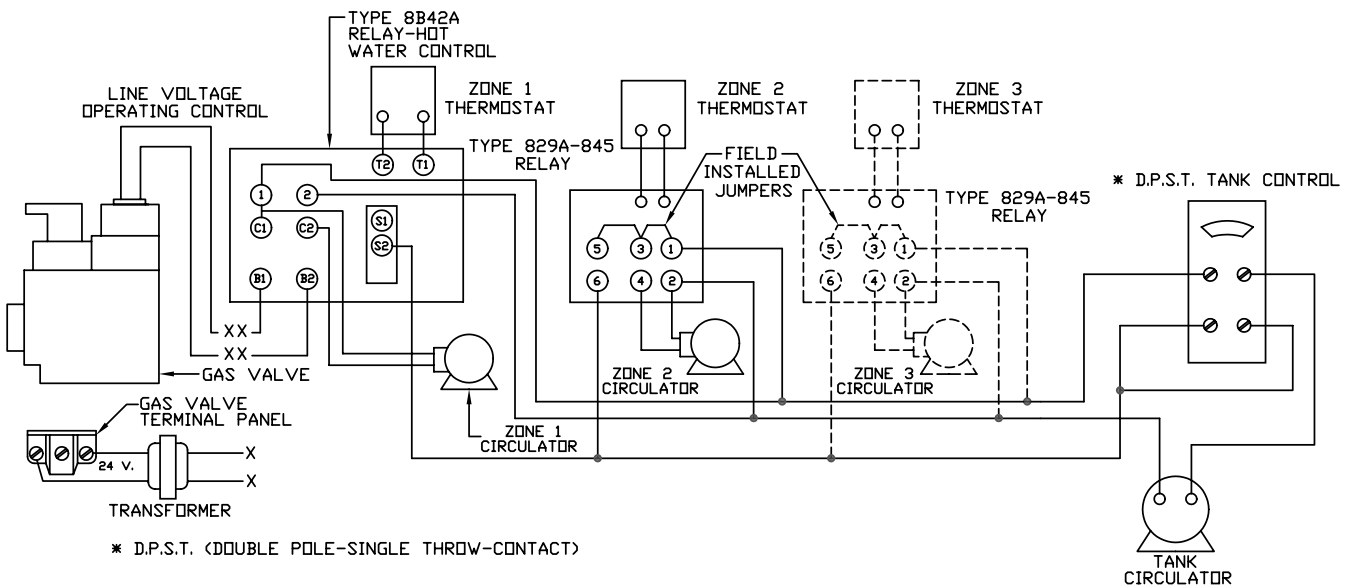

* D.P.S.T. (DOUBLE POLE-SINGLE THROW-CONTACT)

FIG. 2

ZONING WITH CIRCULATORS USING L8124 A, C AND R845A RELAY

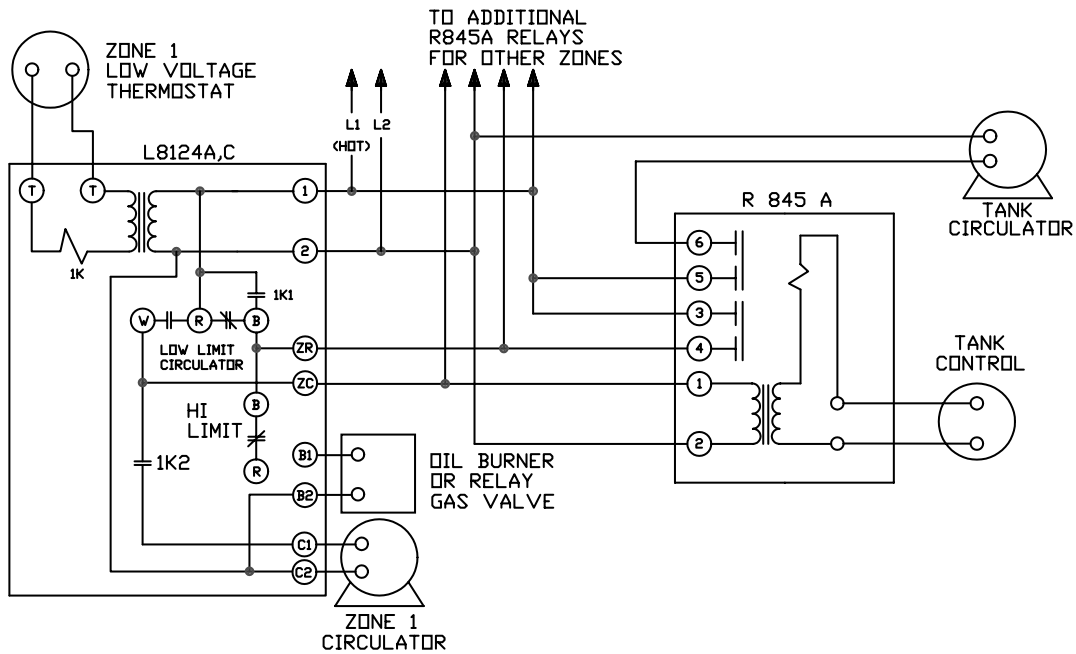

POWER SUPPLY, PROVIDE DISCONNECT MEANS AND OVER LOAD PROTECTION AS REQUIRED.

FIG. 3

ZONING WITH CIRCULATORS USING L8124 E,F AND D.P.S.T. CONTROL. (NO RELAY REQUIRED)

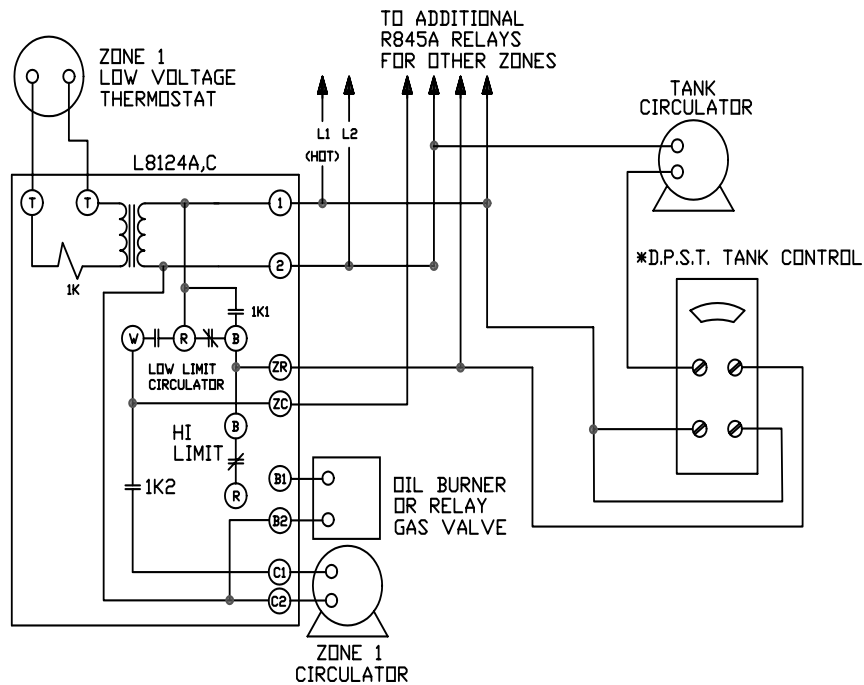

POWER SUPPLY, PROVIDE DISCONNECT MEANS AND OVER LOAD PROTECTION AS REQUIRED.

*D.P.S.T. (DOUBLE POLE-SINGLE THROW- CONTACTS)

FIG. 4

ZONING WITH CIRCULATORS WITH R182D AND R845A RELAY

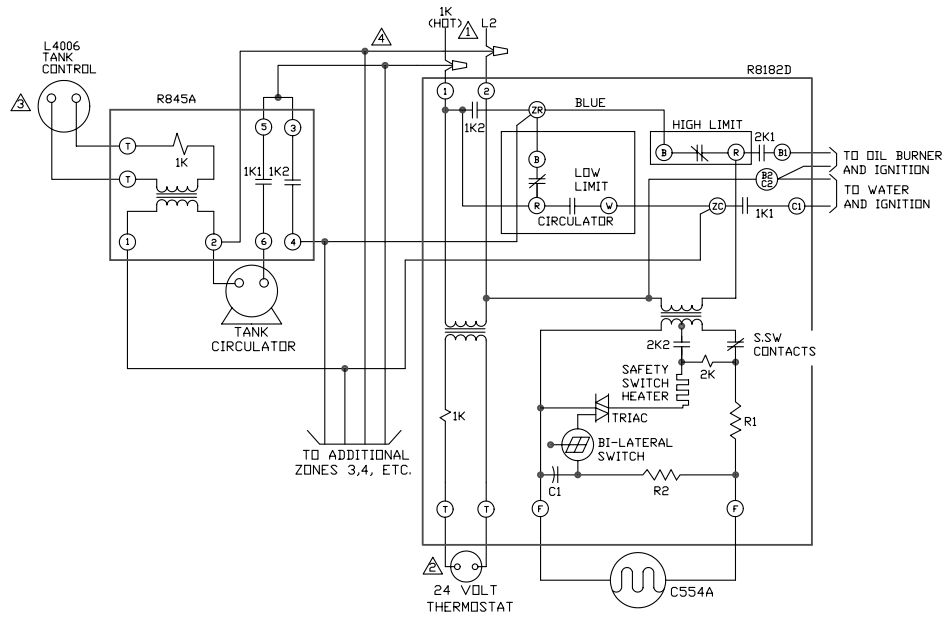

- ⚠ 120 VAC POWER SUPPLY PROVIDE DISCONNECT MEANS AND OVERLOAD PROTECTION AS REQUIRED.
- ⚠ THERMOSTAT HEAT ANTICIPATOR SETTING, 0.2 AMP FOR R8182D
- ⚠ THERMOSTAT HEAT ANTICIPATOR SETTING, 0.4 AMP FOR R845A CONTROL CASE MUST BE CONNECTED TO EARTH GROUND USE
- ⚠ GROUNDING SCREW PROVIDED

FIG. 5

USING CONTROL WITH BUILT IN IDPST SWITCH WITH NO RELAY REQUIRED

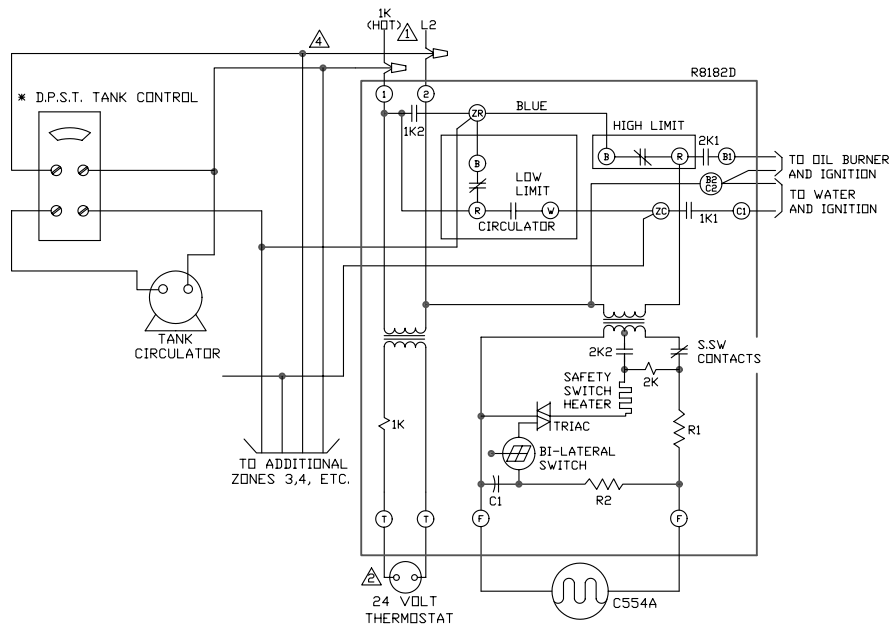

- ⚠ 120 VAC POWER SUPPLY PROVIDE DISCONNECT MEANS AND OVERLOAD PROTECTION AS REQUIRED.
- ⚠ THERMOSTAT HEAT ANTICIPATOR SETTING, 0.2 AMP FOR R8182D
- ⚠ THERMOSTAT HEAT ANTICIPATOR SETTING, 0.4 AMP FOR R845A CONTROL CASE MUST BE CONNECTED TO EARTH GROUND USE
- ⚠ GROUNDING SCREW PROVIDED

FIG. 6

* D.P.S.T. (DOUBLE POLE-SINGLE THROW-CONTACT)

ZONING WITH CIRCULATORS USING L8124 A, C AND R845A RELAY

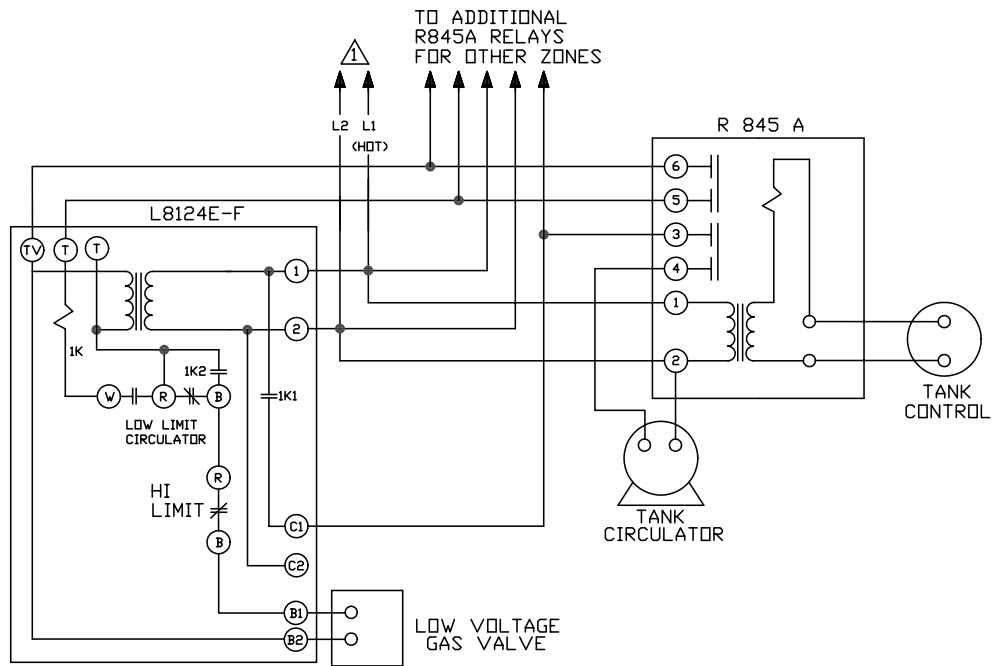

⚠ POWER SUPPLY, PROVIDE DISCONNECT MEANS AND OVER LOAD PROTECTION AS REQUIRED.

FIG. 7

ZONING WITH CIRCULATORS USING L8124 A,C AND D.P.S.T. (NO RELAY REQUIRED)

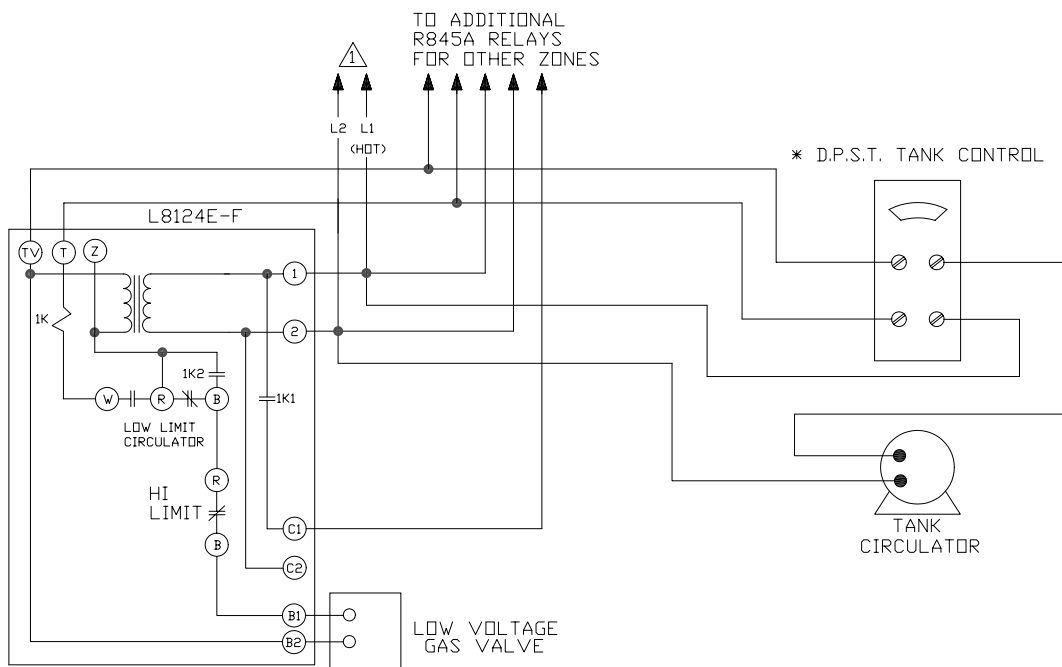

⚠ POWER SUPPLY, PROVIDE DISCONNECT MEANS AND OVER LOAD PROTECTION AS REQUIRED.

*D.P.S.T. (DOUBLE POLE-SINGLE THROW CONTACTS) HONEYWELL L4006G-1006)

FIG. 8

USING L8148A OR L8152A COLD START BOILER CONTROL WITH CIRCULATORS

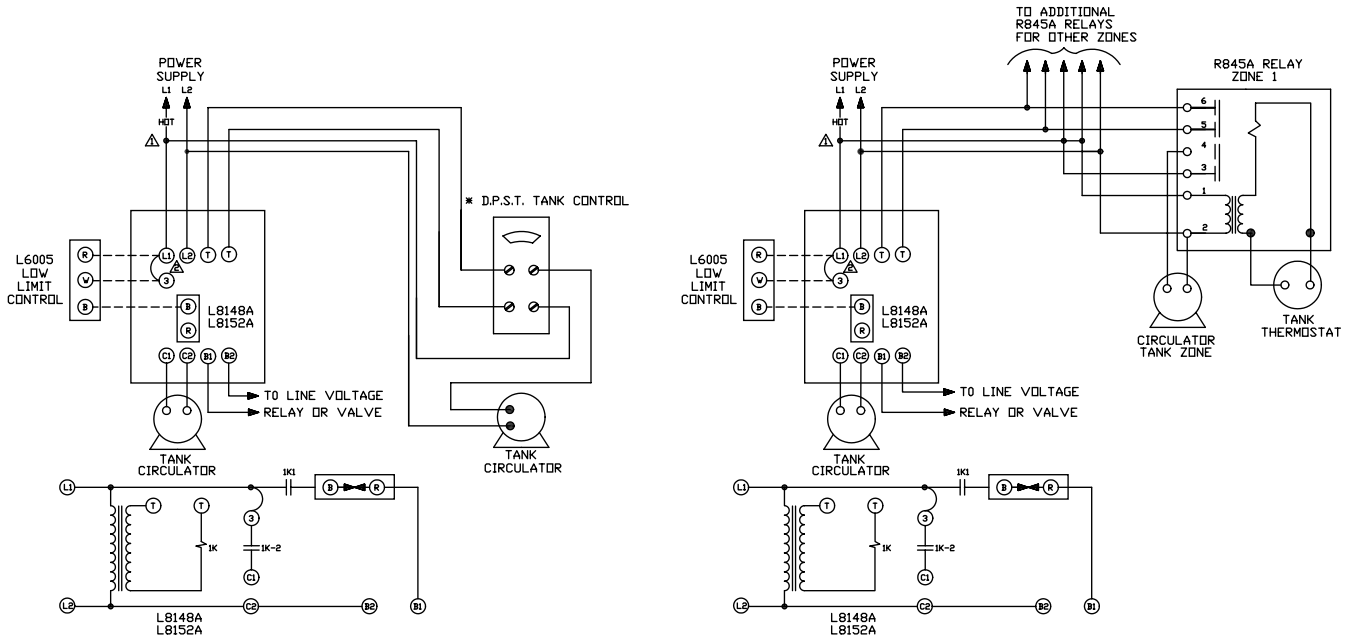

⚠ POWER SUPPLY, PROVIDE DISCONNECT MEANS AND OVER LOAD PROTECTION AS REQUIRED.
 ⚠ WHEN USING LOW LIMIT CIRCULATOR CONTROL, REMOVE L1-3 JUMPER

FIG. 9

PRIORITY ZONE WITH CIRCULATORS

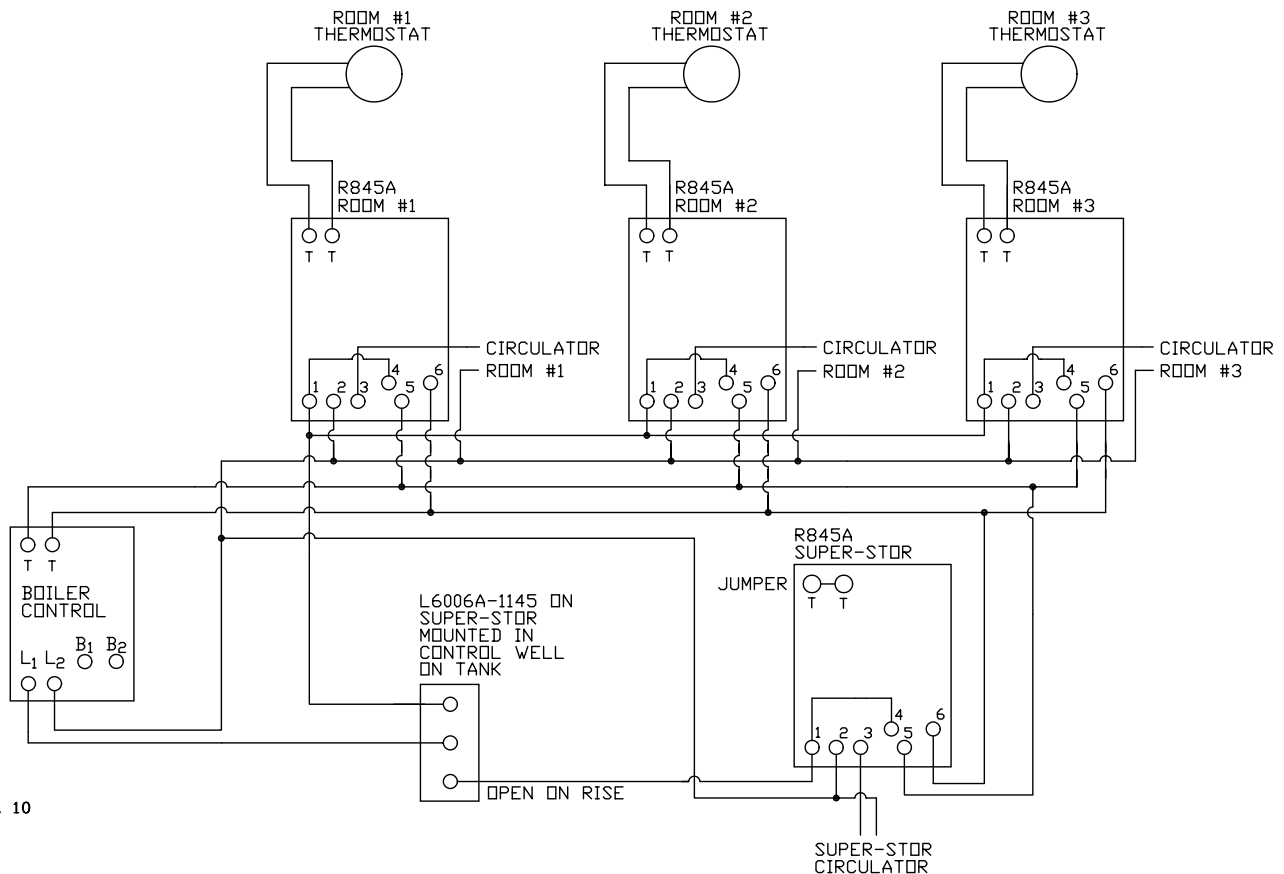

FIG. 10

USING L8148A OR L8152A COLD START BOILER CONTROL WITH ZONE VALVES

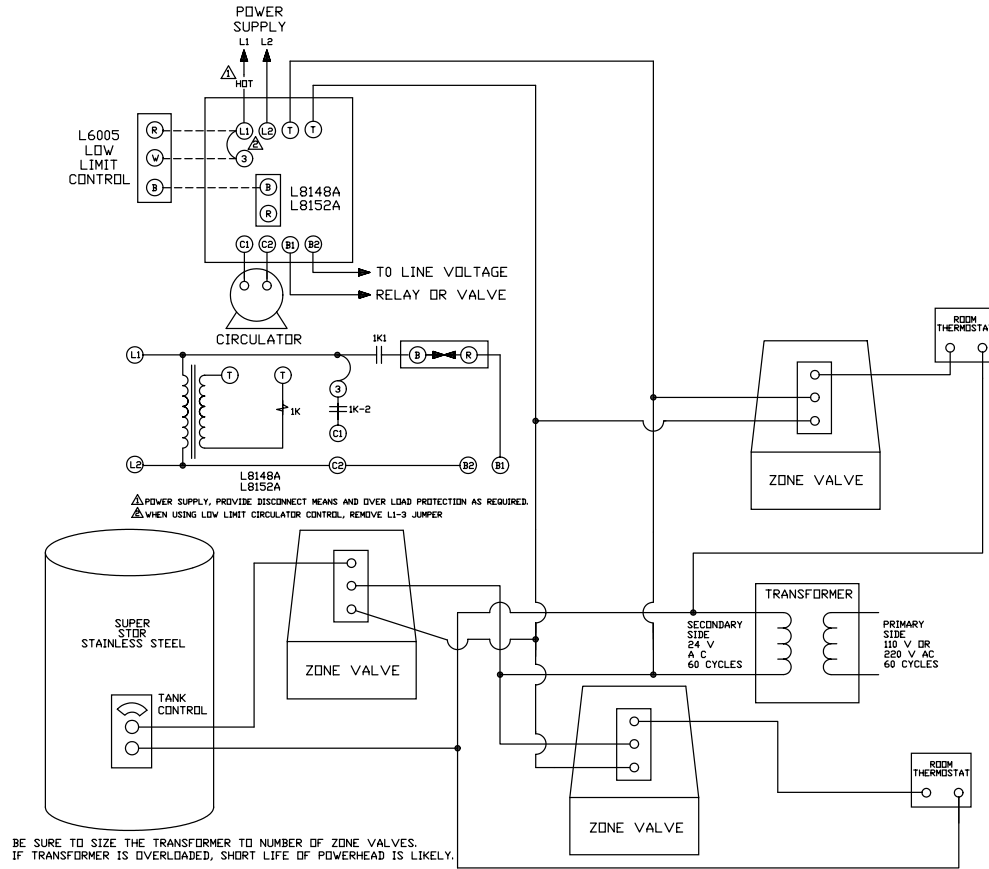

FIG. 11

PRIORITY ZONE WITH ZONE VALVES

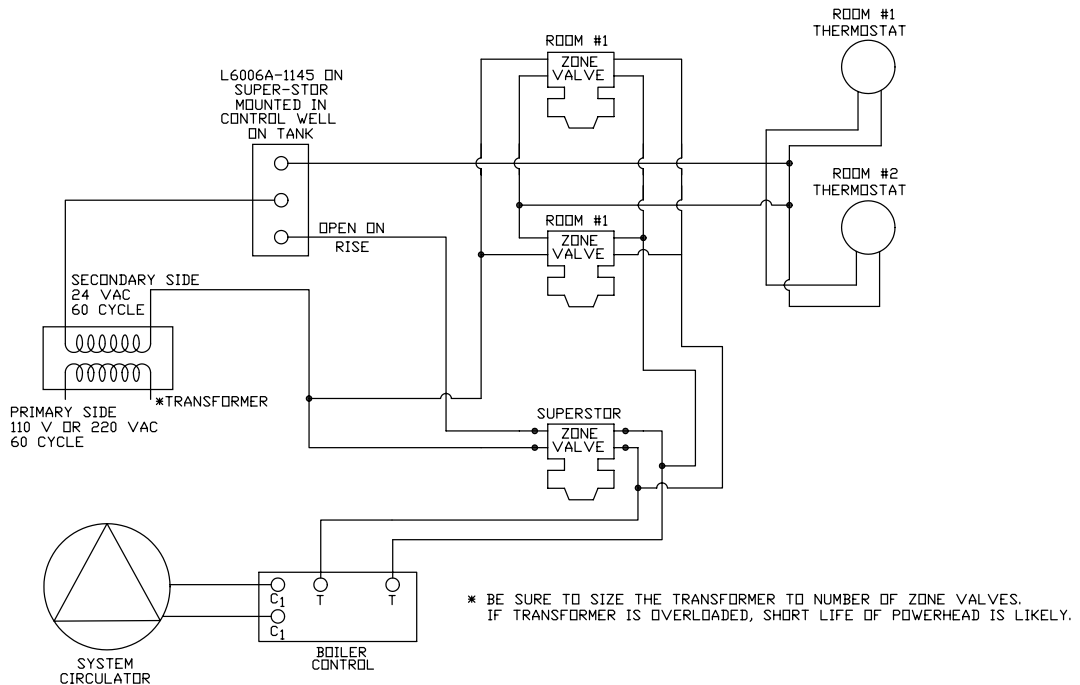

FIG. 12

TROUBLESHOOTING YOUR SUPER STOR ULTRA

NO HOT WATER

| PROBLEM: | POSSIBLE SOLUTION |
|-------------------------------|---|
| A. ZONE VALVE NOT OPENING | A. OPEN MANUALLY TO CHECK |
| B. CIRCULATOR NOT OPERATING | B. CHECK OR REPLACE |
| C. TANK CONTROL SET TOO LOW | C. RAISE TANK TEMPERATURE (SEE WARNING THIS SECTION) |
| D. BOILER CONTROL SET TOO LOW | D. RAISE BOILER TEMPERATURE |
| E. WIRING INCORRECT | E. RECHECK WIRING |
| F. TANK CONTROL FAILURE | F. REPLACE CONTROL |
| G. ZONE VALVE FAILURE | G. REPLACE VALVE |
| H. CIRCULATOR FAILURE | H. REPLACE CIRCULATOR |
| I. AIR TRAP IN LOOP | I. PURGE TO REMOVE AIR |

NOT ENOUGH HOT WATER

| PROBLEM: | POSSIBLE SOLUTION |
|---------------------------------|--|
| A. ZONE VALVE RESTRICTION | A. 1" FULL BORE REPLACE ZONE VALVE |
| B. CIRCULATOR ARROW REVERSED | B. REVERSE CIRCULATOR |
| C. TANK TEMPERATURE TOO LOW | C. ***RAISE TANK TEMPERATURE (SEE WARNING THIS SECTION) |
| D. BOILER TEMPERATURE TOO LOW | D. RAISE BOILER TEMPERATURE |
| E. BOILER SIZED TOO SMALL | E. CHECK SIZING CHART |
| F. DEMAND FLOW RATE TOO HIGH | F. CHECK SIZING CHART |
| G. TANK SIZED TOO SMALL | G. CHECK SIZING CHART |
| H. DEMAND FLOW RATE TOO HIGH | H. INSTALL MIXING VALVE, RAISE TANK TEMP (SEE WARNING THIS SECTION) |
| I. AIR TRAP IN LOOP | I. PURGE TO REMOVE AIR |
| | INSTALL FLOW REGULATOR |
| I. AIR TRAP IN LOOP | I. PURGE TO REMOVE AIR |
| J. HEAT & TANK COME ON TOGETHER | J. RE-CHECK WIRING OR COINCIDENCE |
| | DRAW TANK DOWN AND LOWER HEAT THERMOSTAT. RE-CHECK |
| K. NOT ENOUGH SPACE HEAT | K. BOILER SIZED TOO SMALL, CONSULT CHART |
| L. SLOW RECOVERY | L. CIRCULATOR HEAD CAPACITY TOO LOW |

T & P VALVE DISCHARGES

| PROBLEM: | POSSIBLE SOLUTION |
|---------------------------------|---|
| A. ZONE VALVE RESTRICTION | A. 1" FULL BORE REPLACE ZONE VALVE |
| B. CIRCULATOR ARROW REVERSED | B. REVERSE CIRCULATOR |
| C. TANK TEMPERATURE TOO LOW | C. RAISE TANK TEMPERATURE (SEE WARNING THIS SECTION) |
| D. BOILER TEMPERATURE TOO LOW | D. RAISE BOILER TEMPERATURE |
| E. BOILER SIZED TOO SMALL | E. CHECK SIZING CHART |
| F. DEMAND FLOW RATE TOO HIGH | F. CHECK SIZING CHART |
| G. TANK SIZED TOO SMALL | G. CHECK SIZING CHART |
| H. DEMAND FLOW RATE TOO HIGH | H. INSTALL MIXING VALVE, ***RAISE TANK TEMP (SEE NOTE BELOW) |
| I. AIR TRAP IN LOOP | I. PURGE TO REMOVE AIR |
| | INSTALL FLOW REGULATOR |
| I. AIR TRAP IN LOOP | I. PURGE TO REMOVE AIR |
| J. HEAT & TANK COME ON TOGETHER | J. RE-CHECK WIRING OR COINCIDENCE |
| | DRAW TANK DOWN AND LOWER HEAT THERMOSTAT. RE-CHECK |
| K. NOT ENOUGH SPACE HEAT | K. BOILER SIZED TOO SMALL, CONSULT CHART |
| L. SLOW RECOVERY | L. CIRCULATOR HEAD CAPACITY TOO LOW |

HOT TUBS, SPAS, MULTIPLE SHOWERS, HIGH DEMAND

| PROBLEM: | POSSIBLE SOLUTION |
|--------------------------|---|
| A. NOT ENOUGH HOT WATER | A. CHECK FLOW RATE AND COMPARE TO CHART |
| B. PRESSURE TOO LOW | B. CHECK LINE PRESSURE FOR RESTRICTION |
| C. RECOVERY OF TANK SLOW | C. SLOW START UP BOILER, SEE CHART |
| D. NOT ENOUGH HOT WATER | D. BOILER SIZED TOO SMALL, SEE CHART |
| | DEMAND TOO GREAT, CHECK FLOW RATES AND COMPART TO CHART. INSTALL MIXING VALVE AND OR A FLOW RESTRICTING VALVE AND ***RAISE TANK AND BOILER TEMPERATURE (SEE WARNING THIS SECTION). |

WARNING

When raising tank temperature, you increase the risk of scalding – Please use a water tempering or mixing valve and extreme caution. Consult codes for conformance.

